

Extraction Hoods

Hood for train exhaust

At DSB (The Danish National Railways) they had a challenge with exhaust gas from their diesel locomotives. The hoods, they were using were not working properly, which resulted in exhaust gas polluting the air in the garage. The airflow was too low and the hood was not designed to do the job properly.

Geovent, along with the consulting engineer, the installation company and DSB, ended up with a specialized product for removing exhaust gas fumes from locomotives.

The hood is constructed of galv. sheet metal, and electrically controlled, with a motorized telescopic function, which makes operation easy. The hood can be controlled by a switch, or central BMS, for automatic positioning, when the train is at the correct location. It means, when the train drives into the maintenance garage, the hoods are lowered to a position right above the exhaust pipe of the train and all gas is extracted effectively.

When the staff is done servicing the train, the hood automatically winds up below the roof and the train can leave the garage.

Motor: 3x400V 50Hz

Standard supplied with out control panel, but can be supplied upon request.

Recommended Airflow: App. 3.000 m³/h.

Weight: 100 kg.



Hood 2000 x 700 mm

Ordering table

Art. No.	Description
02-200	Hood 2000 x 700 mm



Dimensions

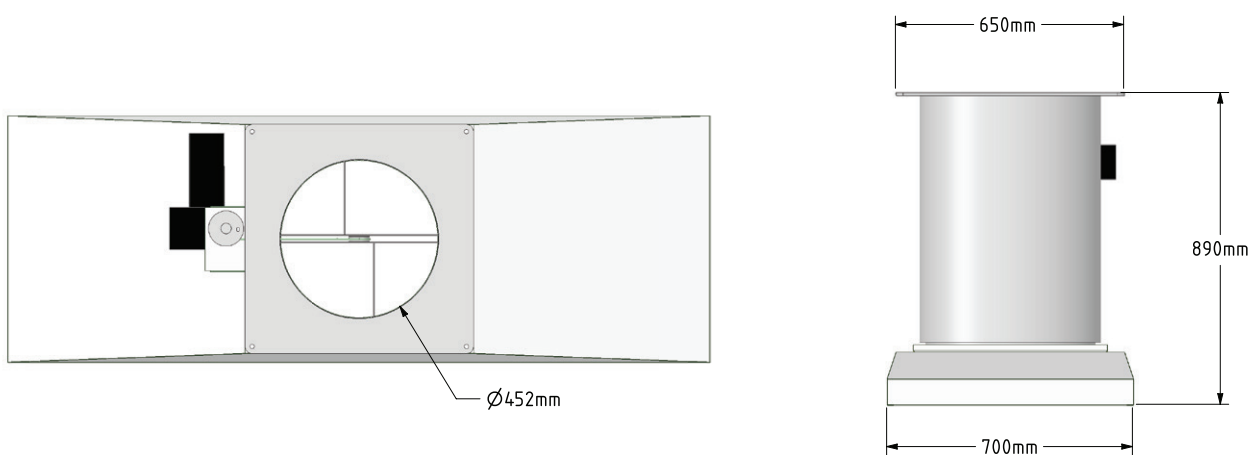
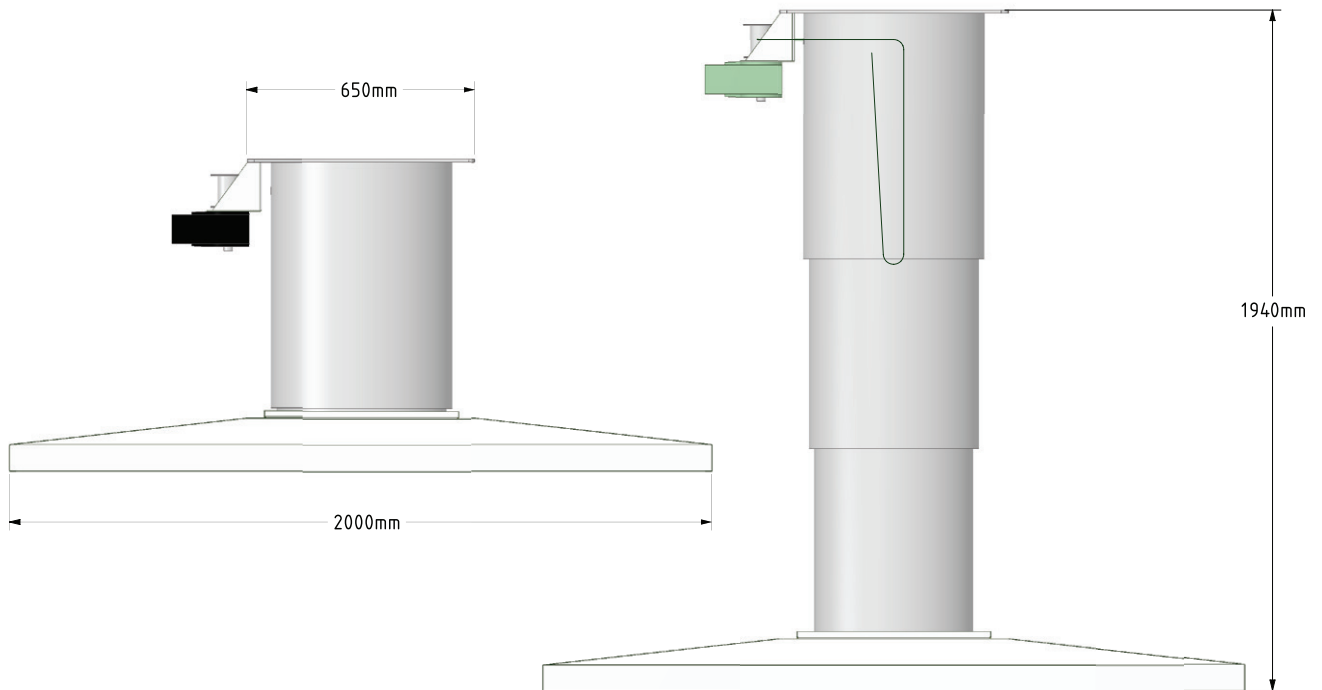

Hood 2000 x 700 mm